

HOST

Slush machine Instruction manual

Model:

HOST1602SM
HOST1603SM



Read this instruction
manual carefully
before use

Safety Instructions

THE APPLIANCE MUST ONLY BE USED BY TRAINED PERSONNEL IN ACCORDANCE WITH THESE INSTRUCTIONS.

- Position on a flat, stable surface.
- Install the appliance where it can be overseen by trained personnel.
- Always carry, store and handle the appliance in a vertical position.
- A service agent/qualified technician should carry out installation and any repairs if required. Do not remove any components or service panels on this product.
- Consult Local and National Standards to comply with the following:
 - Health and Safety at Work Legislation
 - BS EN Codes of Practice
 - Fire Precautions
 - IEE Wiring Regulations
 - Building Regulations
- DO NOT immerse in water, or use steam/jet washers to clean the unit.
- Not suitable for outdoor use.
- Always switch off and disconnect the power supply to the appliance before cleaning.
- This appliance is not intended for use by persons (including children) with reduced physical, sensory or mental capabilities, or lack of experience and knowledge, unless they have been given supervision or instruction concerning the use of the appliance by a person responsible for their safety.
- Children should be supervised to ensure that they do not play with the appliance.
- Keep all packaging away from children. Dispose of the packaging in accordance to the regulations of local authorities.

- If the power cord is damaged, it must be replaced by a recommended qualified technician in order to avoid a hazard.
- DO NOT attempt to modify the appliance in any way.
- NEVER leave the appliance unattended when in use.
- Never use accessories which are not recommended by the manufacturer. They could pose a safety risk to the user and might damage the appliance. Only use original parts and accessories.
- HOST recommend that this appliance should be periodically tested (at least annually) by a Competent Person. Testing should include, but not be limited to: Visual Inspection, Polarity Test, Earth Continuity, Insulation Continuity and Functional Testing.
- HOST recommend that this product is connected to a circuit protected by an appropriate RCD (Residual Current Device).

Caution: Risk of Fire



- Do not store explosive substances such as aerosol cans with a flammable propellant in this appliance.

Warning: Keep all ventilation openings clear of obstruction. Unit should not be boxed in without adequate ventilation.

- **Warning:** Do not use mechanical devices or other means to accelerate the defrosting process, other than those recommended by the manufacturer.
- **Warning:** Do not damage the refrigerant circuit.
- **Warning:** Do not use electrical appliances inside the food storage compartments of the appliance.

Introduction

Please take a few moments to carefully read through this manual. Correct maintenance and operation of this machine will provide the best possible performance from your HOST product.

This appliance is intended for making drinks and cold beverages. If used with dairy-based products and/or when envisaged by law in accordance to the type of product used, it must be equipped with the optional extra of a temperature gauge for the product in the bowl. It is also obligatory to comply with the current regulations and standards concerning the products used.

Note: Only two types of persons can access the appliance:

- **User:** A person who has adequate technical training on how to use the appliance correctly, and full knowledge of routine work on how to maintain, clean and sanitize the appliance.
- **Specialized technician:** A person who has the full knowledge of the appliance concerning the installation, use and servicing of the appliance.

Installation

Note:

Not for use in vans or trailers, food trucks or similar vehicles.

If the unit has not been stored or moved in an upright position, let it stand upright for approximately 12 hours before operation. If in doubt allow to stand.

1. Remove the appliance from the packaging. Make sure that all protective plastic film and coatings are thoroughly removed from all surfaces.
2. To optimize performance and longevity, ensure a minimum clearance of 2.5cm is maintained between the unit and walls and other objects, with a minimum 20cm clearance on the top. **NEVER LOCATE NEXT TO A HEAT SOURCE.**

Before installation, ensure to check that:

- The appliance is installed indoors.
- The room is adequately lit, well-ventilated and hygienic.
- The location of the appliance is flat and solid, and can support its weight.
- The appliance may only operate in places with an ambient temperature ranging between 16°C and 32°C.
- Adequate clearance is kept around the appliance to enable personnel to operate without constraints.

Assembly

Hang the drip tray onto the slot on the front.

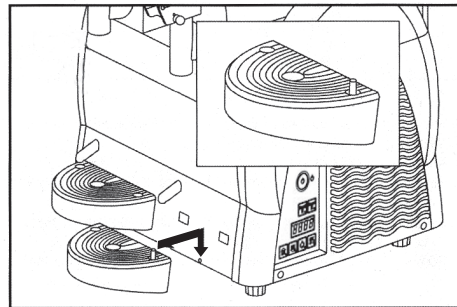

Control panel (Model featured: HOST1603SM)

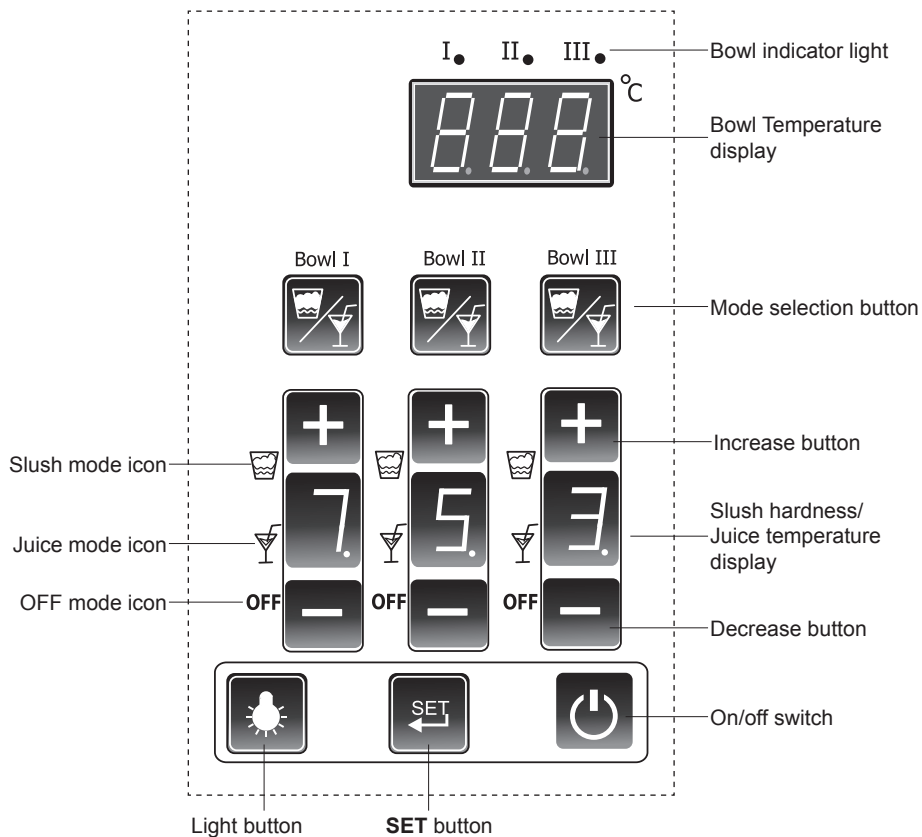

Note: The SET button is designed for adjusting parameters by professional technicians only, which is password protected. Ordinary users/operators should not access it for any purpose.

Note: Before the first time use, ensure to let specialized technician check the appliance functions properly.

Appliances have varied quantity of bowls (Model HOST1602SM has 2 and Model HOST1603SM has 3), so Bowl I means the one on the left hand side of the unit when looking from the front. Bowl II means the middle one...

Operation

Filling

1. Ensure to switch Off and unplug the appliance.
2. **Preparing your product:** HOST recommend that you use syrup mix designed for use in Slush Machines. Dilute and mix the concentrate with water in a container, following the manufacturer's instructions.
NOTE - Any mixture used must have a minimum sugar content of 13% - lower sugar content mixture will freeze solid and can damage the augers and gear motors. Damage caused by using incorrect mix will invalidate the warranty.
3. **Removing the lid:** Lift the rear part to release. Then remove directly.

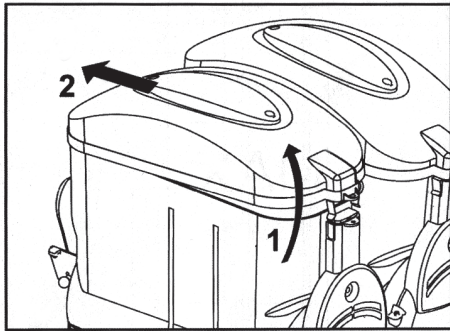

4. Pour the mixture into the bowl.

WARNING: Do not fill the tank with hot liquid. Do not let the level exceed the 'MAX' level line marked on the front of the bowl.

5. Re-locate the lid.



WARNING: There are moving parts inside the bowl, which may cause injuries. Therefore, ensure to turn off and unplug the appliance before carrying out any operations inside the bowl.

Getting started



1. Connect the appliance to a mains power supply.
2. Press the on/off switch .

Selecting the working mode



- Press the mode button  to select the working mode.
- There are 3 modes in total:

Mode	Mode icon	Description
Slush		Slush mode is selected
Juice		Juice mode is selected
OFF	OFF	The bowl will stop stirring and refrigerating.

To serve with slush

1. Press the mode button  to select the slush mode. The icon  illuminates.
2. Press buttons "+" and "-" to select the slush hardness setting from 1 (softest) to 7 (hardest).

To serve with cold drinks

1. Press the mode button  to select the juice mode. The icon  illuminates.
2. Press buttons "+" and "-" to select the juice temperature from 1°C to 7°C.

Note: When the shop is out of service and there is still remaining product in the bowl, we highly recommend setting all bowls to Juice mode, as in this mode bowl stirring and refrigerating are still ON so as to keep the product fresh (Temperature from 1°C to 7°C).

To simply clean the desired bowl

1. Press the mode button  for six seconds.
2. "C" will be shown on the display.

Notes:

- In this mode no refrigerant gas will flow into, but the auger is still rotating to assist the cleaning process. Please fill warm and clean water into the corresponding bowl (not exceeding the maximum level marked on the bowl).
- If desired to perform a thorough cleaning or sanitization to the machine, please ensure the machine is powered off. For details, please see Section "Cleaning, Care & Maintenance".

To use the dispenser

Once the liquid is sufficiently cooled, use the tap lever for dispensing.

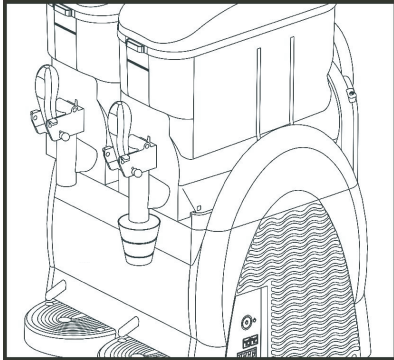

Notes:

- Regularly check the temperature of the product in the bowl, using a standard thermometer, to make sure the product is always kept below the storage temperature.
- NEVER disconnect the machine from the power supply or switch it off using the on/off switch  when there is still product for consuming inside the bowl.
- If the appliance is not used continuously, when used with milk-based products, make sure to:
 - spray sanitizer solution around the spigot area and on the spigot itself (alternatively, wipe with a clean cloth and sanitizer);
 - Or
 - Dispense a small amount of the product from the spigot and discard before dispensing the serving for the customer.

To turn off a certain bowl (for Model HOST1602SM/HOST1603SM)

Note: The bowls work independently. To stop a certain bowl, you just need to turn it off.

1. Press the mode button  to select the OFF mode for the desired. The icon **OFF** illuminates.
2. Under OFF mode, the bowl will stop stirring and refrigerating.

To empty the bowl

Note: The bowl must be cleaned and sanitized at least once a day and more frequently depending on the products used, and in any case, in compliance with the applicable hygiene regulations.

1. Before a bowl is cleaned, it must be emptied.
2. Set the bowl to juice mode. Then release all the liquid from the bowl into a suitable container.
3. Switch off and unplug the appliance.

To turn off the appliance

- **After use:** press the on/off switch  for 3 seconds to turn off the appliance.
- In case of freezing, switch off and unplug the appliance. Then consult a qualified technician.
- Should a fire break out, clear the area immediately to make way for the trained personnel for proper handling.

Cleaning, Care & Maintenance

Warning: Switch off and disconnect from the power supply before any cleaning and maintenance.

- Before cleaning or maintenance, ensure to wear proper personal protections (gloves, glasses, etc.).
- Do not use abrasive cleaning agents as they may leave harmful residues.
- DO NOT rinse the base unit. Instead just wipe the outer surface with a damp cloth.
- Empty and clean the drip trays regularly.
- DO NOT wash any parts in a dishwasher.
- DO NOT dry any parts in a conventional or microwave oven.
- Ensure to carry out any cleaning and sanitization with utmost care and on a regular basis to guarantee the quality of the product dispensed and compliance with mandatory hygiene standards.

- To carry out easy cleaning and maintenance, the upper parts of the side protectors can be removed. When necessary, lift the upper part to remove. Once done with cleaning, re-locate the part in place.

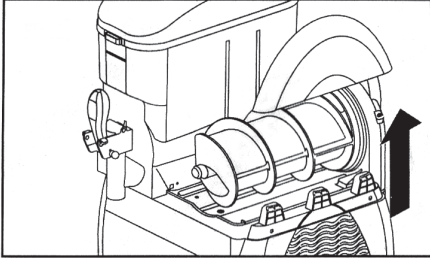

Disassembling the tap assembly

- Disassemble the tap and remove the pin (F) from its seat to release all the other parts.

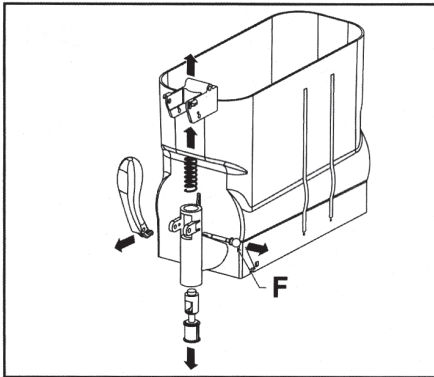

- Wash the parts thoroughly and let them dry.

Removing the bowl

- Remove the bowl lid.
- Raise the front part of the bowl to release it.

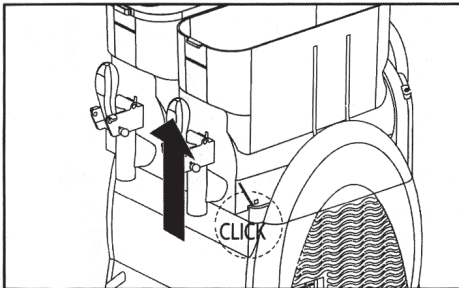

- Remove the bowl from its seat by pushing and tapping lightly on the rear part.

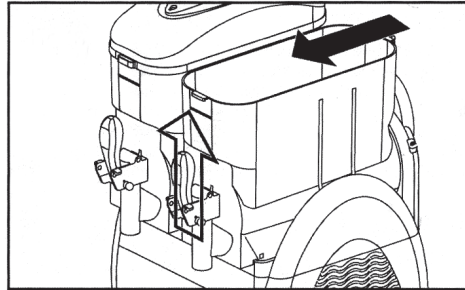

- Take out the auger. Then remove the seals (A and B).

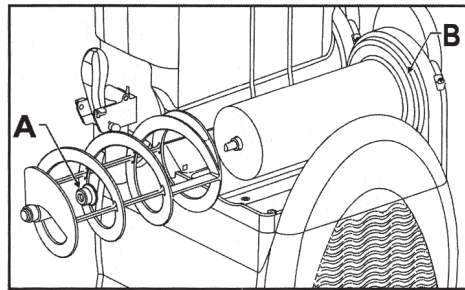

- Clean and sanitize all the dismantled parts (excluding the lid), following below instructions:

- Wipe the parts with a sponge soaked with a sanitizer solution.
- Rinse the parts thoroughly with clean water.
- Soak the parts into the sanitizer solution for about 30 minutes.
- Wash the parts again with clean water.
- Let dry thoroughly.

Cleaning the lid

Caution:

- As the lid is equipped with LED lights, **NEVER** soak it in any type of liquid for cleaning.
- During cleaning, **Never** let water or any liquid come into contact with the electrical parts of the light.

1. Use a clean damp cloth to wipe clean the bottom part of the lid.
2. Wipe clean the whole outer part.

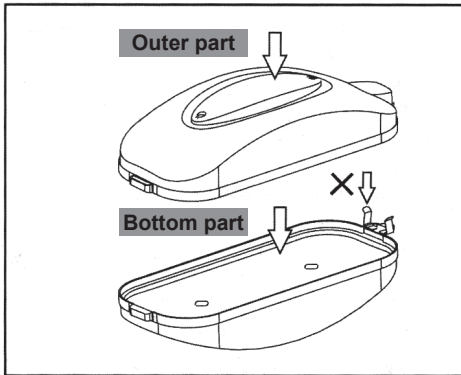

3. Sanitize the bottom part with a sponge previously damped with sanitizer solution.
4. Allow to act for 30 minutes.
5. Wipe the bottom part twice or more with a clean sponge soaked with clean water.
6. Let the lid dry well.

Caution: NEVER attempt to clean/sanitize the lid while it is installed in the appliance.

Re-assembly

1. Apply the seal (A) onto the auger as shown.

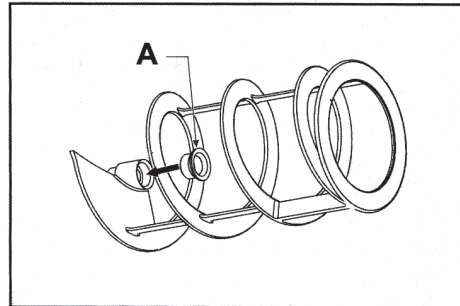

Always ensure to check the seal integrity. Should it be worn, replace with a new one immediately. Replace the seal (A) at least once a year.

2. Using the Vaseline provided, lubricate the seal (A) in the area as shown.

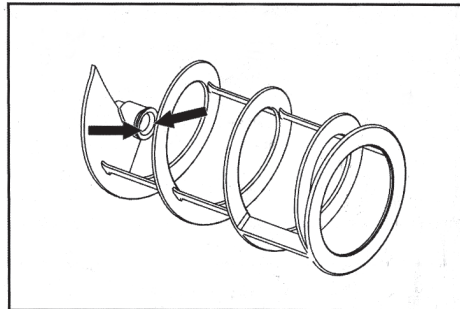

3. Apply the seal (B), lubricating the entire surface as indicated by the arrows.

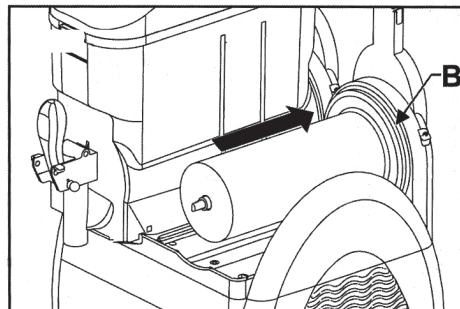

4. Introduce the auger, engaging head (C) with shaft (D). If necessary, rotate the auger to engage it.

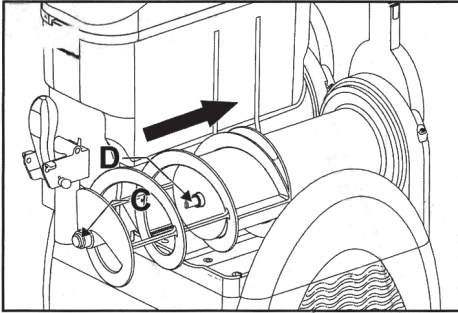

5. **Setting the bowl back in place:** Slightly raise head (C) of the auger so that it meets the seat (E) provided in the bowl.

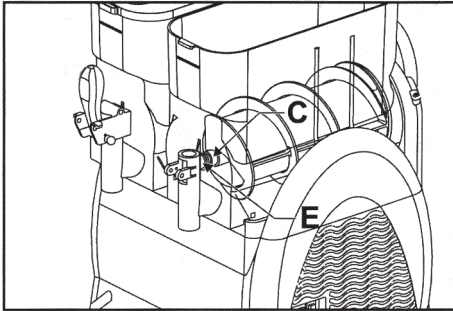

6. Press the bowl downward until it get engaged as shown.

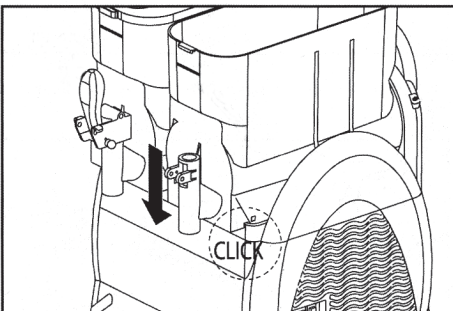

7. To refit the tap assembly, follow below instructions:

- Using the vaseline provided, adequately lubricate the cap (Y), and refit the components.
- Introduce the pin (F) while keeping the tap lever steady.

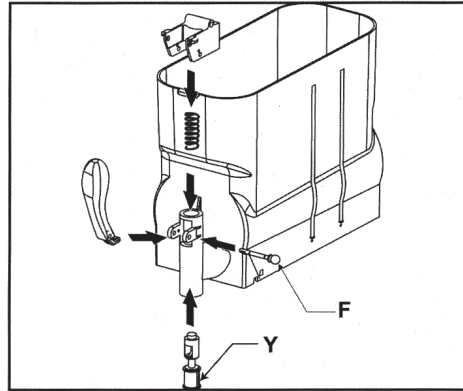

Always ensure to lubricate the cap. Otherwise, product leakage from the tap may occur.

Rinsing cycle

Caution: After re-assembly and before re-starting the appliance for serving, make sure to carry out the rinsing cycle.

1. Fill the bowl with clean water.
2. Run the cleaning mode. For details, please see Section "To simply clean the desired bowl".
3. Turn off the appliance. Then empty the bowl.

Replacing the light bulb

Light bulb replacement should be carried out only by professional technician. For details, please refer to our service manual available online.

Cleaning the condenser

Periodically cleaning the condenser can extend the life of the appliance. HOST recommend that a qualified technician should clean the condenser.

Troubleshooting

A qualified technician must carry out repairs if required.

Fault	Probable Cause	Solution
The appliance is not working	The unit is not switched on	Check the unit is plugged in correctly and switched on
	Plug or lead is damaged	Replace plug or lead
	Fuse in the plug has blown	Replace the fuse
	Mains power supply fault	Check mains power supply
The dispenser is not cooling	Coolant leak	Consult a qualified technician
	Fan motor failed	Consult a qualified technician
	Airflow obstructed to the condenser	Increase the gap between appliance and obstacles/heat source
Tap leaks	Tap piston not lubricated well	Lubricate the tap piston
	Tap piston is defective	Replace the tap piston
Product leaks from the back of the bowl	Bowl not fitted correctly	Check the positioning of the bowl
	Bowl seal not lubricated well	Lubricate the bowl seal
	Bowl seal is defective	Replace the bowl seal
Loud noises	Front seal is not applied correctly	Put the seal correctly
	Seal not lubricated well	Lubricate the seal
Tap does not distribute	Ice blocked inside the bowl	Turn off the unit to let ice melt

Service

Should your appliance have a fault, please visit the Service section of the HOST website.

Technical Specifications

Model	Voltage	Power (W)	Current (A)	Bowls	Capacity (litres)	Refrigerant
HOST1602SM	220-240V~50Hz	740W	3.5A	2	24	R290 135g
HOST1603SM	220-240V~50Hz	1150W	5.8	3	36	R290 148g

Model	Dimensions (H x W x D) (mm)	Weight (kg)	Noise level
HOST1602SM	810 x 470 x 515	50.7	<70 dB
HOST1603SM	810 x 670 x 515	66.2	

Due to our continuing program of research and development, the specifications herein are subject to change without notice.

Electrical Wiring

The appliance is supplied with a 3 pin BS1363 plug and lead.

The plug is to be connected to a suitable mains socket.

The appliance is wired as follows:

- Live wire (coloured brown) to terminal marked L
- Neutral wire (coloured blue) to terminal marked N
- Earth wire (coloured green/yellow) to terminal marked E

This appliance must be earthed.



If in doubt consult a qualified electrician.

Electrical isolation points must be kept clear of any obstructions. In the event of any emergency disconnection being required they must be readily accessible.

Compliance

The WEEE logo on this product or its documentation indicates that the product must not be disposed of as household waste. To help prevent possible harm to human health and/or the environment, the product must be disposed of in an approved and environmentally safe recycling process. For further information on how to dispose of this product correctly, contact the product supplier, or the local authority responsible for waste disposal in your area.



HOST parts have undergone strict product testing in order to comply with regulatory standards and specifications set by international, independent, and federal authorities.



All rights reserved. No part of these instructions may be produced or transmitted in any form or by any means, electronic, mechanical, photocopying, recording or otherwise, without the prior written permission of HOST.
Every effort is made to ensure all details are correct at the time of going to press, however, HOST reserve the right to change specifications without notice.



www.host-appliances.com

HOST1602SM_HOST1603SM_EN_A5_v1_2022/08/12