

HOST

Display Chiller Instruction manual

Model:

HOST1107UR
HOST1108UR



Read this instruction
manual carefully
before use

Safety Instructions

- Position on a flat, stable surface.
- A service agent/qualified technician should carry out installation and any repairs if required. Do not remove any components or service panels on this product.
- Consult Local and National Standards to comply with the following:
 - Health and Safety at Work Legislation
 - BS EN Codes of Practice
 - Fire Precautions
 - IEE Wiring Regulations
 - Building Regulations
- DO NOT use jet/pressure washers to clean the appliance.
- DO NOT use the appliance outside.
- DO NOT use this appliance to store medical supplies.
- DO NOT use electrical appliances inside the appliance (e.g. heaters, ice cream makers etc.).
- DO NOT allow oil or fat to come into contact with the plastic components or door seal. Clean immediately if contact occurs.
- DO NOT store products on top of the appliance.
- Bottles that contain a high percentage of alcohol must be sealed and placed vertically in the refrigerator.
- Always carry, store and handle the appliance in a vertical position and move by holding the base of the appliance.
- Always switch off and disconnect the power supply to the unit before cleaning.
- Keep all packaging away from children. Dispose of the packaging in accordance with the regulations of local authorities.
- If the power cord is damaged, it must be replaced by a recommended qualified technician in order to avoid a hazard.

- This appliance is not intended for use by persons (including children) with reduced physical, sensory or mental capabilities, or lack of experience or knowledge, unless they have been given supervision or instruction concerning the use of the appliance by a person responsible for their safety.
- Children should be supervised to ensure that they do not play with the appliance.
- HOST recommend that this appliance should be periodically tested (at least annually) by a Competent Person. Testing should include, but not be limited to: Visual Inspection, Polarity Test, Earth Continuity, Insulation Continuity and Functional Testing.
- HOST recommend that this product is connected to a circuit protected by an appropriate RCD (Residual Current Device).

Caution: Risk of Fire



- Do not store explosive substances such as aerosol cans with a flammable propellant in this appliance.

Warning: Keep all ventilation openings clear of obstruction. Unit should not be boxed in without adequate ventilation.

- **Warning:** Do not use mechanical devices or other means to accelerate the defrosting process, other than those recommended by the manufacturer.
- **Warning:** Do not damage the refrigerant circuit.
- **Warning:** Do not use electrical appliances inside the food storage compartments of the appliance.

Installation

Note:

Not for use in vans or trailers, food trucks or similar vehicles.

If the unit has not been stored or moved in an upright position, let it stand upright for approximately 12 hours before operation. If in doubt allow to stand.

1. Remove the appliance from the packaging. Make sure that all protective plastic film and coatings are thoroughly removed from all surfaces.
2. To optimize performance and longevity, ensure a minimum clearance of 2.5cm is maintained between the unit and walls and other objects, with a minimum 20cm clearance on the top.
NEVER LOCATE NEXT TO A HEAT SOURCE.

Note: Before using the appliance for the first time, clean the shelves and interior with soapy water.

3. Set the brakes on the castors to keep the appliance in position.

Reversing the door

Depending on the location of the appliance, it may be necessary to change the direction the door opens by changing the side of the door handle.

To reverse the door handle:

1. The door handle is on the left side.

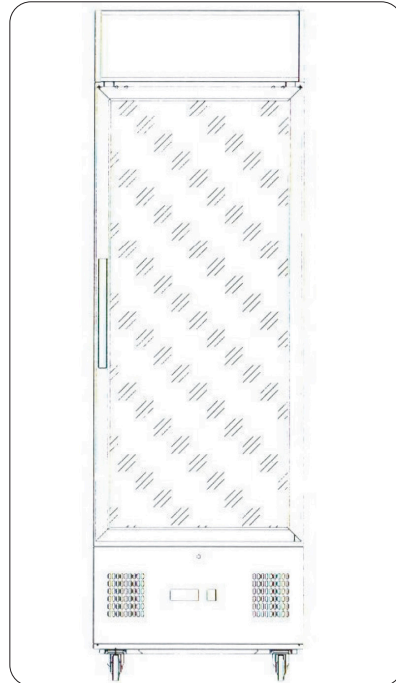

2. Disassemble the front panel.

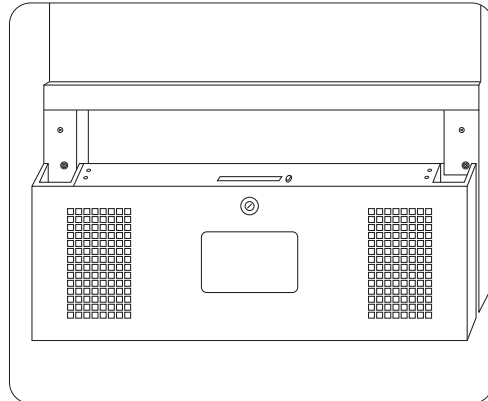

3. Cut the slot on the front panel and install the hinge inside.

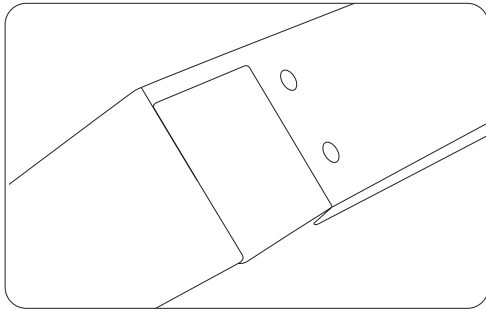
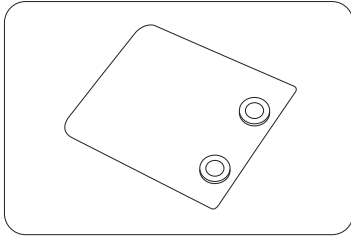

4. Disassemble the right lower hinge and install it on the left lower side.

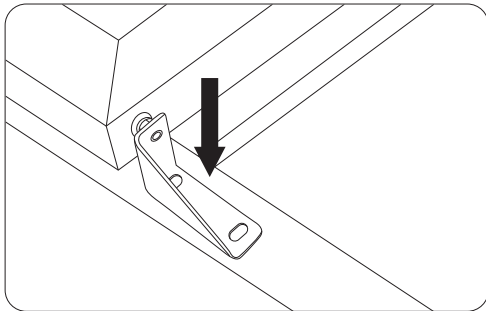
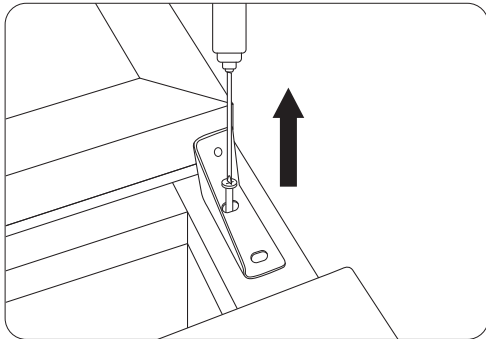

5. Reverse the door.

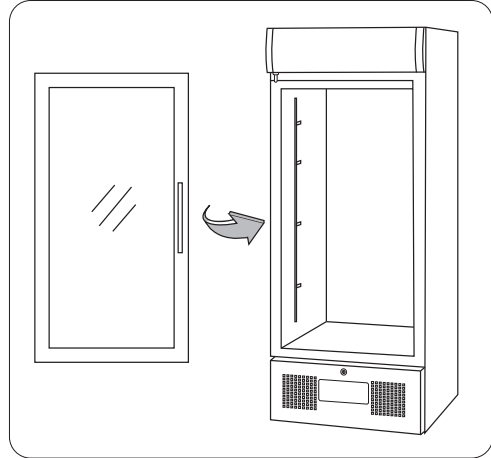

6. Disassemble the right upper hinge.

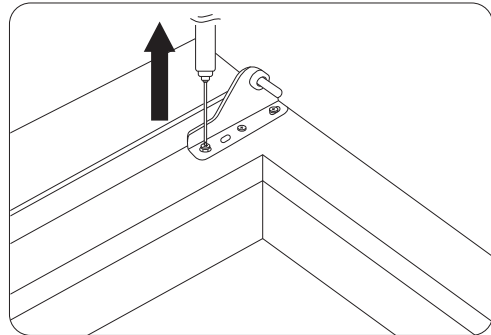

7. Install the left upper hinge.

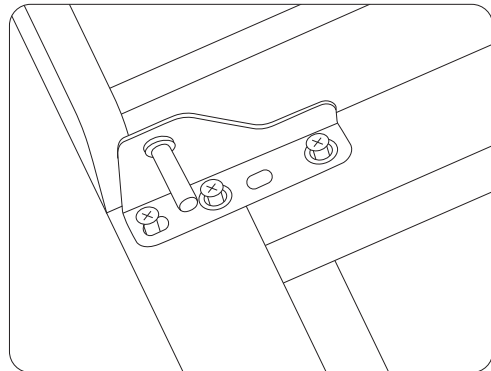

- At last, install the front panel. Now the door handle is on the right side.

Operation

Control Panel

The control panel is located below the doors on the front of the appliance.

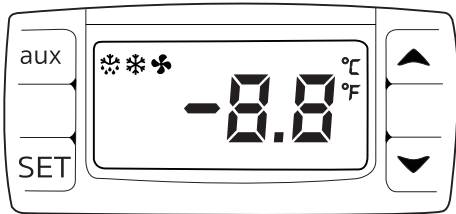

To unlock / lock the keyboard press ▲ and ▼ together for 3 seconds. Display will flash PON (unlocked) / POF (locked).

Turn On

- Close the door of the appliance.
- Connect the appliance to a mains power supply.
- Turn the light switches On [I] or Off [O] as desired.

Set the Operating Temperature

- Press the **SET** button. The display will flash.
- Press the ▲ or ▼ buttons to display the required temperature.
- Press the **SET** button to store the temperature.

Manual Defrost

Press and hold the defrost button “aux” for 2 seconds to begin a manual defrost. The defrost light illuminates.

Storing Food

To get the best results from your HOST appliance, follow these instructions:

- Only store foodstuffs in the appliance when it has reached the correct operating temperature.
- Do not place uncovered items as below inside the appliance, as this can lead to a damaged and leaking evaporator, and thus void your warranty:
hot food, hot liquids, acidic fluids, acidic products.
- Wrap or cover food where possible.
- Do not obstruct the fans inside the appliance.
- Avoid opening the doors for prolonged periods of time.

Lock/Unlock the Doors

- A lock is fitted to the door to ensure foodstuffs are kept secure within your HOST appliance.
- Use the keys provided to lock/unlock the door.

Cleaning, Care & Maintenance

Switch off and disconnect from the power supply before cleaning.

- Clean the interior of the appliance as often as possible.
- Do not use abrasive cleaning agents. These can leave harmful residues.
- Clean the door seal with warm soapy water.
- Always wipe dry after cleaning.
- Do not allow water used in cleaning to run through the drain hole into the evaporation pan.
- Take care when cleaning the rear of the appliance. Sharp edges can cut.

Condensation will form in refrigeration with frequent opening of the doors and on hot humid days, please ensure condensation is allowed to drain properly or is wiped dry.

Replacing the Interior Lamp

WARNING: Allow the lamp to cool before replacing. The lamp remains hot immediately after use.

1. Turn Off and disconnect the appliance from the mains power supply.
2. Unscrew the plastic lamp cover.
3. Remove the lamp by twisting it from the lamp sockets.
4. Insert the new lamp and replace the cover.

Cleaning the Condenser

Periodically cleaning the condenser can extend the life of the appliance.
HOST recommend that a qualified technician should clean the condenser.

Troubleshooting

A qualified technician must carry out repairs if required.

| Fault | Probable Cause | Solution |
|------------------------------|-----------------------------|--|
| The appliance is not working | The unit is not switched on | Check the unit is plugged in correctly and switched on |
| | Plug or lead is damaged | Replace plug or lead |
| | Fuse in the plug has blown | Replace the fuse |
| | Mains power supply fault | Check mains power supply |

| Fault | Probable Cause | Solution |
|---|---|--|
| The appliance turns on, but the temperature is too high/low | Too much ice on the condenser | Defrost the appliance |
| | Condenser blocked with dust | Consult a qualified technician |
| | Doors are not shut properly | Check doors are shut and seals are not damaged |
| | Appliance is located near a heat source or air flow to the condenser is being interrupted | Move the refrigerator to a more suitable location |
| | Ambient temperature is too high | Increase ventilation or move appliance to a cooler position |
| | Unsuitable foodstuffs are being stored in the appliance | Remove any excessive hot foodstuffs or blockages to the fan |
| | Appliance is overloaded | Reduce the amount of food stored in the appliance |
| The appliance is leaking water | The appliance is not properly levelled | Adjust the screw feet to level the appliance (if applicable) |
| | The discharge outlet is blocked | Clear the discharge outlet |
| | Movement of water to the drain is obstructed | Clear the floor of the appliance (if applicable) |
| | The water container is damaged | Consult a qualified technician |
| The appliance is unusually loud | Loose nut/screw | Check and tighten all nuts and screws |
| | The appliance has not been installed in a level or stable position | Check installation position and change if necessary |
| The display lamp does not illuminate | Lamp needs replacing | Consult a qualified technician |

Service

Should your appliance have a fault, please visit the Service section of the HOST website.

Technical Specifications

| Model | Voltage | Power | Current | Temperature Range | Capacity (Litres) | Refrigerant | Dimensions (H x W x D) (mm) | Weight (kg) |
|------------|---------------|-------|---------|-------------------|-------------------|----------------|-----------------------------|-------------|
| HOST1107UR | 230V~ 50Hz | 230W | 1.5A | 2°C to 8°C | 218 | R600a (50g) | 1692 x 530 x 575 | 124 |
| HOST1108UR | | 340W | 2A | 2°C to 8°C | 336 | R600a (78g) | 1982 x 620 x 570 | 134 |

| Model | Maximum load of each shelf |
|------------|----------------------------|
| HOST1107UR | 12.5kg |
| HOST1108UR | 15kg |

Due to our continuing program of research and development, the specifications herein are subject to change without notice.

| | |
|--|--|
| Optimal Storage temperature for food storage: | 4°C |
| Impact of temperature settings on food waste: | This appliance shall be operated in its designated operating range to reduce food waste from spoilage |
| Ordering spares parts: | To order spare parts, please visit the link below: www.host-appliances.com Then type the relative item code and Spares |
| Minimum period of spares parts to be available: | Door handles, door hinges, knobs, dials and buttons, door gaskets, peripheral trays, baskets and racks for storage, as appropriate to the appliance, will be made available to both end users and professional users for a minimum of eight years after the last unit of the model is placed on the market. A broader selection of parts will also be made available to Professional users for this period |
| To find the model information on the product: | The location of the model No. is on the plate on the interior right-hand wall (and on the rear) of the appliance |

Electrical Wiring

The appliance is supplied with a 3 pin BS1363 plug and lead.

The plug is to be connected to a suitable mains socket.

The appliance is wired as follows:

- Live wire (coloured brown) to terminal marked L
- Neutral wire (coloured blue) to terminal marked N
- Earth wire (coloured green/yellow) to terminal marked E

This appliance must be earthed.



If in doubt consult a qualified electrician.

Electrical isolation points must be kept clear of any obstructions. In the event of any emergency disconnection being required they must be readily accessible.

Compliance

The WEEE logo on this product or its documentation indicates that the product must not be disposed of as household waste. To help prevent possible harm to human health and/or the environment, the product must be disposed of in an approved and environmentally safe recycling process. For further information on how to dispose of this product correctly, contact the product supplier, or the local authority responsible for waste disposal in your area.



HOST parts have undergone strict product testing in order to comply with regulatory standards and specifications set by international, independent, and federal authorities.



All rights reserved. No part of these instructions may be produced or transmitted in any form or by any means, electronic, mechanical, photocopying, recording or otherwise, without the prior written permission of HOST.
Every effort is made to ensure all details are correct at the time of going to press, however, HOST reserve the right to change specifications without notice.



www.host-appliances.com

HOST1107UR_HOST1108UR_EN_A5_v1_2022/08/17