

Freedom to create

Positive and negative blast chilling, thawing, proofing and retarder-proofer, pasteurization, slow cooking, maintaining the temperature, drying...are just some of the functions that can be managed immediately and precisely, individually or by connecting them in a single flow.

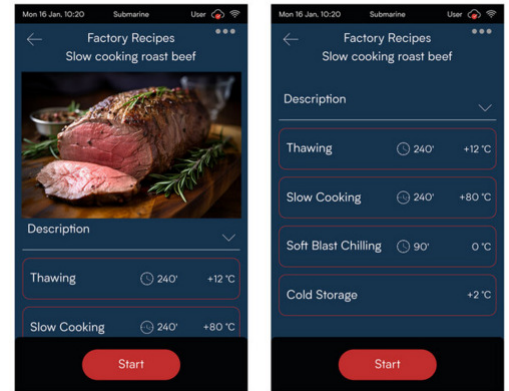

Model: SBM-061-HA-R290

Tray type: 6 x 1/1 GN - 6 x EN1

SUBMARINE MULTIFUNCTION, CABINET - 6 X GN 1/1 - 6 X EN1. +85 / -40 °C - AIR CONDENSING UNIT

+3°C	-40°C / -18°C	-5°C / -40°C	-2°C / +18°C	-18°C / -21°C	+10°C / +16°C	+35°C / +65°C	-18°C / +32°C	+60°C / +85°C	+10°C / +32°C
Soft or hard blast chilling	Anisakis Killer	Continuous cycle	Storage	Negative Storage	Crystallisation	Dehydration	Retarder - Proofer	Slow Cooking	Proofing
-50°C / +70°C	+60°C / +85°C	+30°C / +55°C	-18°C / +3°C	-18°C	-35°C / -18°C	+38°C / +50°C			
Maintaining	Pasteurisation	Melting Chocolate	Thawing	Soft or hard freezing	Tapeworm Killer	Yogurt	Wifi Connection	Friulinox Cold Cloud	Ecological refrigerant gas

CE CB IPX4

COMMANDS, CONTROLS AND SAFETY DEVICES

- 7" touch screen color display with control interface
- Quick-release heated core probe with 4 measuring points
- Control-activated chamber sanitisation system with active ions (HI-GIENE)
- Photo-identifiable processes
- USB connection for uploading and downloading data/recipes
- IoT connectivity as standard

STRUCTURAL CHARACTERISTICS

- External Scotch Brite satin finish stainless steel.
- High density CFC and HCFC-free PU insulation (42 kg/m3).
- AISI 304 stainless steel panel construction
- Patented chamber humidity-injecting system
- Stainless steel internal coating with fully rounded corners
- Die-moulded and leakproof internal base
- Anti-condensation heating element located on the box under the magnetic seal stop
- Strongbox ergonomic handle
- Magnetic seal on 4 sides of the door
- Indirect-flow electric fans - made of composite material - on the product
- Side guide-supporting uprights with 18 mm-pitch holes
- Compressor-protecting automatic-reset thermal circuit breaker
- Copper-aluminium evaporating coil, cataphoresis-painted with non-toxic epoxy resin
- Copper condensing coil with high thermal efficiency aluminium fins

REFRIGERANT GROUP

- Automatic defrost and defrost water self evaporating without the use of energy.
- R290 ecological refrigerant gas
- Hermetic compressor

VERSIONING

- Model with wheels
- Model with left hinged door

OPTIONAL TO BE REQUESTED WHEN ORDERING

TS-061-208-1N-60Hz-HO: 208-1N-60HZ-HO

CA-061: WOODEN CRATE PACKAGING

KRT-01: WHEEL KIT WITH BRAKE

PSX-061: LEFT HINGED DOOR

EXTRA ACCESSORIES THAT CAN BE INSTALLED FOLLOWING PURCHASE

FAC: LIMESCALE FILTER WITH CARTRIDGE

CFA: REPLACEMENT CARTRIDGE FOR LIMESCALE FILTER

FAI-061: STAINLESS STEEL DUST FILTER

GRI-EN1: STAINLESS STEEL GRILL - EN1

GRI-GN11: STAINLESS STEEL GRILL - GN 1/1

CGM: PAIR OF MULTI-STEP GUIDES

SMM007: M MONO-POINT PROBE - 0,7 MT.

SMU007: MULTIPOINT PROBE - 0,7 MT.

SSV007: VACUUM PROBE - 0,7 MT.

DE5: HAND SHOWER

DIMENSIONS

Width	mm	790
Depth	mm	820
Height	mm	900
Door Span Width	mm	670
Internal Depth	mm	435
Package width	mm	830
Package depth	mm	920
Package height	mm	1050
Package volume	m ³	10,39
Weight	Kg	110
Weight with package	Kg	150

TECHNICAL DATA

Working temperature	°C	+85 / -40 °C
Motor		Air condensing unit
PU insulation - Thickness	mm	60
Refrigerant - Type		R290

CAPACITY

N° Trays - h 20	N.	10
N° Trays - h 40	N.	6
N° Trays - h 65	N.	5
Distance between layers - h 20	mm	35
Distance between layers - h 40	mm	52.5
Distance between layers - h 65	mm	70
Minimum distance between layers	mm	17.5
Capacity		6 x 1/1 GN - 6 x EN1

POWER SUPPLY

Max electric power	kW	1,951
Cooling power	kW	1,137
Max consumption	A	10,39
Power supply voltage	V	230
Electrical_Phase		1
Frequency	Hz	50

YIELDS AND PERFORMANCE

Yield per cycle +90/+3°C	kg	35
Yield per cycle +90/-18°C	kg	25
Yield per BC cycle according to standard EN17032 (+65/+10°C)	kg	30
Yield per BF cycle according to standard EN17032 (+65/-18°C)	kg	20
BC consumed energy according to standard EN17032	kW h / kg	0.062
BF consumed energy according to standard EN17032	kW h / kg	0.221
BC blast chilling consumption according to standard EN17032	kWh/Ciclo	1.87
BF blast chilling consumption according to standard EN17032	kWh/Ciclo	4.42

* BT - Evap. temp. -25°C / Cond. temp. +45°C.

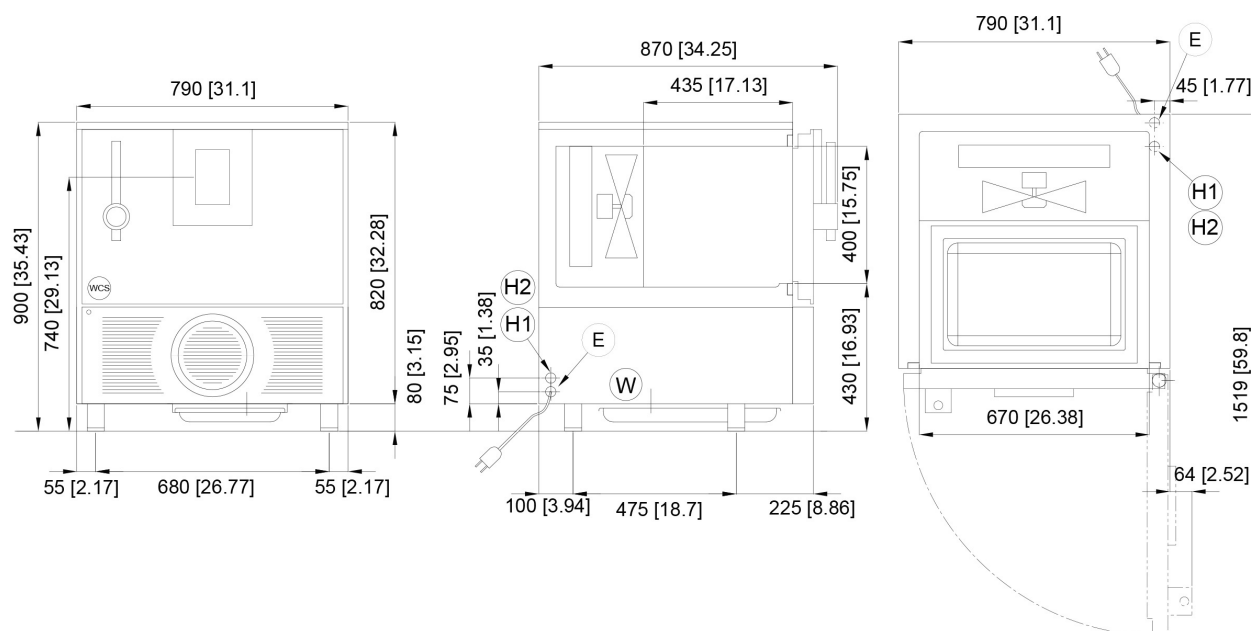

DIMENSIONI mm
DIMENSIONS [in]

- E** CONNESSIONE ELETTRICA
ELECTRICAL CONNECTION
- W** CONNESSIONE SCARICO OPZIONALE
OPTIONAL DRAIN CONNECTION
- H1** CONNESSIONE INGRESSO H2O 1/2"
INLET WATER CONNECTION 1/2"
- H2** CONNESSIONE USCITA H2O 1/2"
EXHAUST WATER CONNECTION 1/2"
- WCS** CONNESSIONE OPZIONALE PER DOCCETTA ESTERNA
CONNECTION OPTIONAL FOR HAND SHOWER